

The GERBERSpreader 250s spreads material rolls weighing up to 250 kg (550 lbs.) at speeds up to 100 meters per minute without tension. Precision selvage and end alignment technology maximizes material utilization.

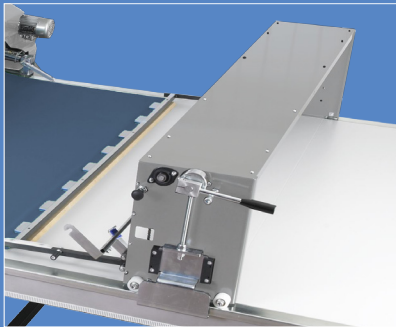

Optional end catcher system

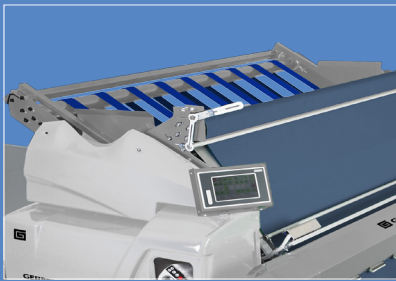

Optional extra large cradle for high-loft materials



Optional tray for flat folded material up to 40 kgs.



Optional trailer for flat folded material up to 300 kgs.

GERBERSpreader 250s



Engineered for Heavy and/or Large-Diameter Material Rolls

- The GERBERSpreader 250s spreads material rolls weighing up to 250 kg (550 lbs.)
- A large cradle option is available for automotive and transport seating applications where foam is bonded to a face textile (foam laminate) and spread from very large rolls.

Spreads Material Without Tension

- Intelligent cradle feed system delivers tension-free spreading for the entire lay.

Maximizes Material Utilization

- The system is equipped with adjustable infrared photocells to ensure accurate selvage alignment.
- Precision end alignment technology eliminates end loss.

Fast and Safe

- Spreads material at speeds up to 100 meters per minute.
- To uphold worker safety, the spreader's cradle feed system is equipped with an electric cradle tilt that enables fast and easy loading/unloading and threading/rewinding of material rolls.
- An optional loading system lifts heavy fabric rolls from the floor to the spreader cradle and vice versa making it easy and safe to load and unload rolls.
- Sensors located on both sides of the GERBERSpreader immediately halt the system when an obstacle is in its path.
- The system complies with CE safety standards.

Built-in Intelligence

- To accelerate operator training and minimize set up time, the system is operated using a touch screen panel that guides the user to input marker lengths and overlap/splice points.
- A multi-function throttle enables the operator to control threading/rewinding/cutting of material and the start/stop of spreading with one hand.
- The system stores up to 10 custom fabric settings and can step spread up to 50 markers (sections) and 50 colors.
- A variable speed, two-way cutting device intelligently lifts automatically to accommodate thicker spreads.

GERBER spreader 250s

Flexible

- The system is available in widths of 160cm (63 in.) 180cm (71 in.) 200cm (79 in.) 220cm (87 in.).
- Available for left- or right-hand operation.
- Fixed or movable end catchers available.
- Optional accessories are offered for spreading reverse-wound or flat folded material and for spreading material face-to-face.

Single Source for Cutting Room Automation

- The GERBERspreader 250s is designed to integrate seamlessly with Gerber's G model static (air flotation) and conveyor spreading tables, which, when combined with Gerber's industry-leading cutting systems delivers a total cutting room solution.

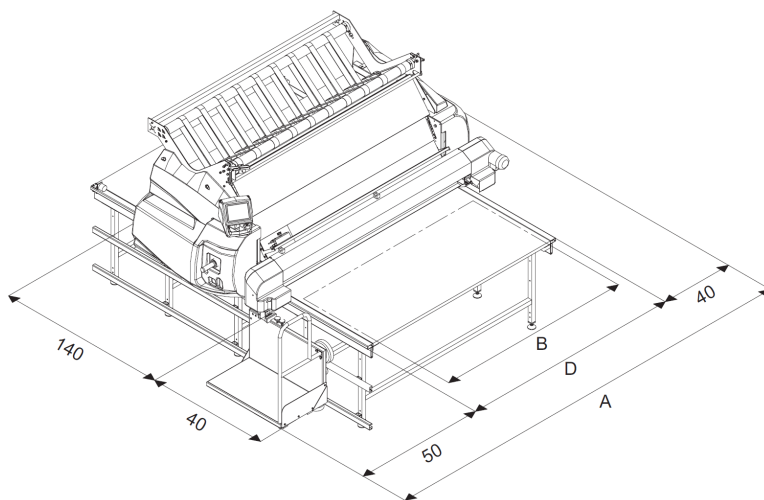

B = Material Width 160 - 180 - 200 - 220 cm
D = Table Width B + 20 cm

Provides Business-critical Data

- The system compiles data on amount of material used in a roll and amount lost to defects or flaws.

Backed by a Global Support Network

- Gerber service protects your investment by ensuring that your Gerber systems are running at peak performance levels. We accomplish this through a global network of highly-skilled technical support staff and by providing the most comprehensive service offerings, highest-quality consumables and aftermarket products available.

Supported Spreading Modes

- One way face up
- Face to face with end catchers (optional zig zag accessory needed)

Technical Specifications

Characteristics		
Maximum roll diameter	90 cm*	35.4 in*
Maximum roll weight	250 kg	550 lbs
Spreading height - one way	22 cm	8.66 in
Spreading height - zig-zag	12 cm	4.72 in
Maximum speed per minute	100 m	328 ft
Loading height over table top	600 mm	23.6 in
Total height over table top	1088 mm	42.83 in
Spreader weight	550 kg	1212.5 lbs
Absorbed power	4,2 kWh	

* Extra large cradle (120 cm) available for automotive foam-laminated materials or other high-loft fabrics.